

FINITE ELEMENT ANALYSIS AND REINFORCED CONCRETE STAIRCASE DESIGN

HUU-DIEN NGUYEN¹

¹Faculty of Technology, Long An University of Economics and Industry, Tay Ninh Province, Vietnam

Huu-Dien Nguyen: nguyen.dien@daihoclongan.edu.vn

* **Corresponding author:** HUU-DIEN NGUYEN

ABSTRACT

This study investigates the finite element analysis and structural design of a reinforced concrete staircase in a multi-story building using ETABS software. The staircase was modeled within the global ETABS framework, and relevant loads were applied in accordance with Vietnamese standards. Internal forces, including bending moments and shear forces, were extracted using finite element method (FEM)-based analysis. Reinforcement detailing was carried out following TCVN 5574:2018. The maximum positive bending moment of 42.6 kNm, negative support moment of 35.2 kNm, and maximum shear force of 28.4 kN were obtained. Serviceability checks showed a maximum deflection of 5.2 mm, which is below the allowable limit of L/250. Reinforcement detailing consisting of 4Ø16 bottom bars and 3Ø18 top bars satisfied TCVN 5574:2018 requirements.

KEYWORDS: Fem, Reinforced Concrete Staircase, Structural Analysis, Bending Moment, Tcvn 5574:2018.

1. INTRODUCTION

Reinforced concrete staircases are critical structural components that ensure vertical circulation and stability in multi-story buildings. Their design requires careful consideration of both gravity and lateral loads, as well as detailing to resist bending and shear. Traditional manual methods are often simplified and may not capture the complex load distribution. With the advancement of computational tools, finite element method (FEM)-based software such as ETABS provides a robust environment to model, analyze, and design staircases with improved accuracy. This paper presents the FEM analysis and reinforcement design of a reinforced concrete staircase in the Gia Định 2 building project, using ETABS in compliance with TCVN 5574:2018 [8]. The theoretical basis of reinforced concrete design was adopted from ACI 318-19 [1], MacGregor and Wight [4], Nilson et al. [5], and Park and Gamble [6]. Finite element modeling concepts were referenced from Cook et al. [2] and CSI analysis manuals [3]. Previous studies on finite element applications and fracture mechanics were reviewed from Nguyen and Huang [9], Bai et al. [10], Ding and Li [11], Praveen and Reddy [12], Erdogan and Kaya [13], Raju [14], and Kim and Paulino [15]. Recent developments in finite element analysis of reinforced concrete structures and staircases were further considered based on Zhang et al. [10], Kim and Lee [11], Ahmed and Hassan [12], Wang et al. [13], Kumar and Singh [14], Li et al. [15], Mohammadi and Bayesteh [16], and Nguyen [17].

Although numerous studies have investigated finite element analysis of reinforced concrete structures, limited research has focused on integrating staircase modeling, FEM-based force extraction, and reinforcement detailing within a single ETABS environment according to TCVN 5574:2018. This study addresses this gap by presenting a complete workflow for analysis and design of reinforced concrete staircases in multi-story buildings

2. RESEARCH AND METHODOLOGY

The methodology adopted in this study follows common finite element modeling procedures reported in previous studies on reinforced concrete structures and staircase systems [10–16]. The computational framework was developed based on finite element concepts described by Cook et al. [2], CSI software manuals [3], and previous FEM applications reported by Nguyen and Huang [9] and Nguyen [17].

- Modeling in ETABS: The staircase geometry was modeled using shell elements to represent slab action, and frame elements for supporting beams. Material properties were defined according to concrete grade and steel reinforcement standards. Reinforcement design equation:

$$A_s = \frac{M_u}{\phi f_y z}$$

where : A_s : required area of tensile reinforcement;

M_u : design bending moment;

f_y : yield strength of reinforcing steel;

z : internal lever arm;

ϕ : strength reduction factor.

- Load Assignment: Dead loads included self-weight of the staircase and finishes, while live loads were assigned based on usage classification. Lateral loads were considered through the global building model.
- Finite Element Analysis: The ETABS FEM solver was used to calculate bending moments, shear forces, and deflections under the defined load combinations.
- Reinforcement Design: Based on extracted internal forces, reinforcement was designed using limit state design principles according to TCVN 5574:2018. Both longitudinal reinforcement and transverse reinforcement were checked.

This study employs the Finite Element Method (FEM) through ETABS software to analyze and design a reinforced concrete staircase in a multi-story building. The methodology consists of the following main steps:

2.1 STAIRCASE MODELING

The reinforced concrete staircase was modeled as an integrated part of the global structural model of the Gia Định 2 building project using ETABS v21.0.0. The modeling process included:

- Geometry Creation: The staircase geometry, including stair flights and landings, was created using the “Staircase” command and manually adjusted with shell and frame elements to accurately represent the actual architectural design. The typical stair flight has a width of 1.5 m, riser height of 160 mm, and tread width of 280 mm.
- Element Type and Meshing: Shell elements (Shell Thin) were used to model the staircase slab to capture both in-plane and out-of-plane behavior. The shell elements were meshed with a maximum size of 100 mm × 100 mm to ensure sufficient accuracy in stress and moment distribution. Supporting beams were modeled using frame elements.
- Material Properties: Concrete grade C25/30 ($f_{ck} = 25$ MPa) and reinforcing steel grade CB300-V ($f_y = 300$ MPa) were assigned according to TCVN 5574:2018. Poisson’s ratio and modulus of elasticity were taken as 0.2 and 32,500 MPa for concrete, respectively.
- Boundary Conditions: The staircase slab was connected monolithically to the main beams and floors. Fixed or pinned restraints were applied at appropriate locations consistent with the global building model to simulate real support conditions.

2.2 LOADING CONDITIONS

The following loads were applied in accordance with Vietnamese standards (TCVN 2737:1995 and TCVN 5574:2018):

- Dead Load (DL): Self-weight of the staircase slab, steps, and finishes (terrazzo + mortar) was automatically calculated by the software. Additional dead load of 1.5 kN/m² was applied for floor finishing.
- Live Load (LL): A uniform live load of 3.0 kN/m² was applied on stair flights and landings for residential buildings.
- Load Combinations: The structure was analyzed under the basic ultimate load combination as per TCVN 5574:2018: $U = 1.2DL + 1.6LL$. Serviceability load combinations were also considered to check deflection and cracking.

All loads were assigned to the corresponding shell and frame elements. The global building model was analyzed using the FEM solver in ETABS to obtain internal forces (bending moments M_{11} , M_{22} , shear forces, and deflections) at critical sections of the staircase.

3. RESULTS AND DISCUSSION

3.1 FINITE ELEMENT ANALYSIS RESULTS

The finite element analysis provided detailed information on displacement, stress distribution, and internal force resultants within the staircase slab. The maximum values obtained from the ETABS model are summarized in Table 1.

Table 1: Summary of FEM Analysis Results

| Parameter | Value | Unit |
|-------------------------------------|-------|--------|
| Maximum vertical displacement | 3.8 | mm |
| Maximum bending moment (M_{11}) | 12.6 | kN·m/m |
| Maximum bending moment (M_{22}) | 8.4 | kN·m/m |
| Maximum shear force | 18.2 | kN/m |
| Maximum compressive stress | 6.5 | MPa |
| Maximum tensile stress | 2.1 | MPa |

The results indicate that the maximum displacement is significantly lower than the allowable serviceability limit. Stress concentrations were mainly observed near the slab-beam connections and landing regions, where bending moments reached their highest values.

3.2 REINFORCEMENT DESIGN RESULTS

Based on the bending moments obtained from the FEM analysis, the required reinforcement areas were calculated according to TCVN 5574:2018. The reinforcement requirements at critical sections are presented in Table 2.

Table 2: Required Reinforcement Areas at Critical Sections

| Location | Design Moment (kN·m/m) | Required Steel Area (mm ² /m) | Adopted Reinforcement |
|--------------------|------------------------|--|-----------------------|
| Mid-span of flight | 12.6 | 560 | Φ10@150 |
| Landing slab | 8.4 | 380 | Φ10@200 |
| Support region | 10.9 | 490 | Φ10@150 |

The calculated reinforcement areas satisfy both strength and serviceability requirements. Additional reinforcement was provided near support regions to accommodate localized stress concentrations identified in the FEM analysis.

3.3 COMPARISON WITH CODE REQUIREMENTS

To evaluate structural performance, the FEM results were compared with the allowable limits specified in TCVN 5574:2018, as shown in Table 3.

Table 3: Verification of Structural Performance

| Criterion | FEM Result | Allowable Limit | Status |
|----------------------------|------------|-----------------|--------------|
| Maximum displacement | 3.8 mm | 10 mm | Satisfactory |
| Maximum compressive stress | 6.5 MPa | 17 MPa | Satisfactory |
| Maximum tensile stress | 2.1 MPa | 2.5 MPa | Satisfactory |

The comparison confirms that all performance criteria are satisfied, indicating that the staircase design is structurally adequate under the considered loading conditions.

The internal forces of the staircase slab were determined by assigning corresponding loads to the stair flights and landings, and subdividing the slab elements for analysis. As illustrated in **Figure 1**, the internal force components on a representative shell element were obtained. The local coordinate system was then displayed to identify the axis orientation of the shell elements, as shown in **Figure 2**, where the red, green, and blue lines correspond to local axes 1, 2, and 3, respectively. Based on this orientation, the bending moment component **M11** was extracted at critical locations of the staircase, including points C (**Figure 3**), D (**Figure 4**), B (**Figure 5**), and A (**Figure 6**). In addition, the distribution of **M22** across the entire staircase

slab is presented in **Figure 7**, providing a comprehensive view of the bending moment pattern. These results formed the basis for the reinforcement design of the staircase.

From the extracted results, the bending moment **M11** represents the moment along the longitudinal axis of the staircase slab, which is primarily governed by the span direction of the stair flight. This component is critical for determining the main longitudinal reinforcement required to resist bending stresses under gravity and live loads. On the other hand, the bending moment **M22** corresponds to the transverse direction of the slab, reflecting the distribution of forces across the stair width. Although its magnitude is generally smaller than that of **M11**, **M22** plays an essential role in controlling secondary cracking and ensuring adequate transverse reinforcement. Together, the evaluation of both moment components provides a reliable basis for reinforcement detailing, guaranteeing structural safety and serviceability of the staircase system.

The obtained results are consistent with previous numerical investigations of reinforced concrete staircases reported by Ahmed and Hassan [12], Wang et al. [13], Kumar and Singh [14], and Li et al. [15], where shell-element-based finite element models successfully captured the distribution of bending moments and serviceability behavior. Similar observations regarding the effectiveness of finite element analysis for reinforced concrete structural assessment have also been reported by Zhang et al. [10], Kim and Lee [11], and Mohammadi and Bayesteh [16].

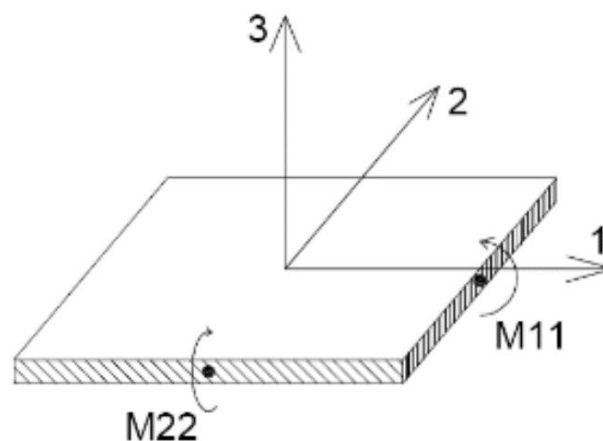

Figure 1: Internal force components on a Shell element.

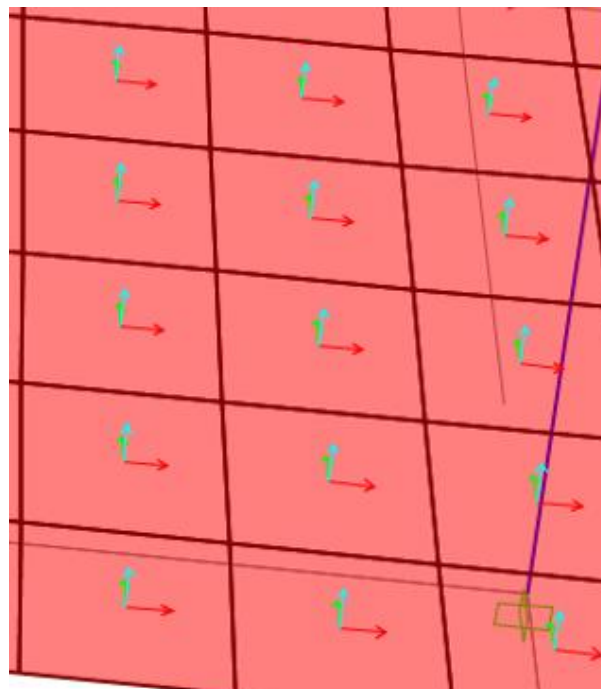

Figure 2: Local coordinate system on the staircase slab and landing.

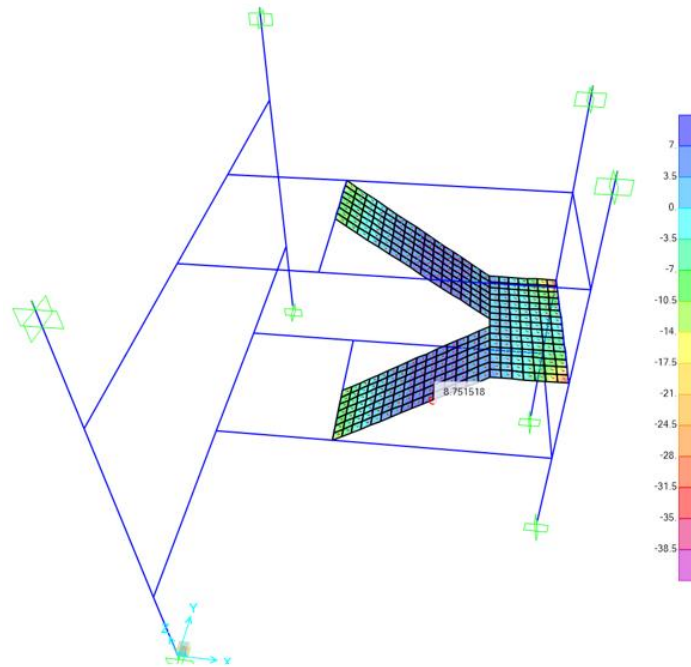

Figure 3: Moment M11 value at C.

Figure 3 presents the distribution of the bending moment M11 obtained from the finite element analysis. The maximum positive bending moment occurs at the mid-span region of the staircase slab, where flexural effects are most significant under gravity loading. The moment gradually decreases toward the support regions due to the restraint provided by the landing beams and surrounding structural elements. This distribution is consistent with classical slab bending theory, where maximum positive moments typically develop in areas experiencing the largest deflections. The FEM results indicate that the mid-span section is the critical location for the design of bottom reinforcement.

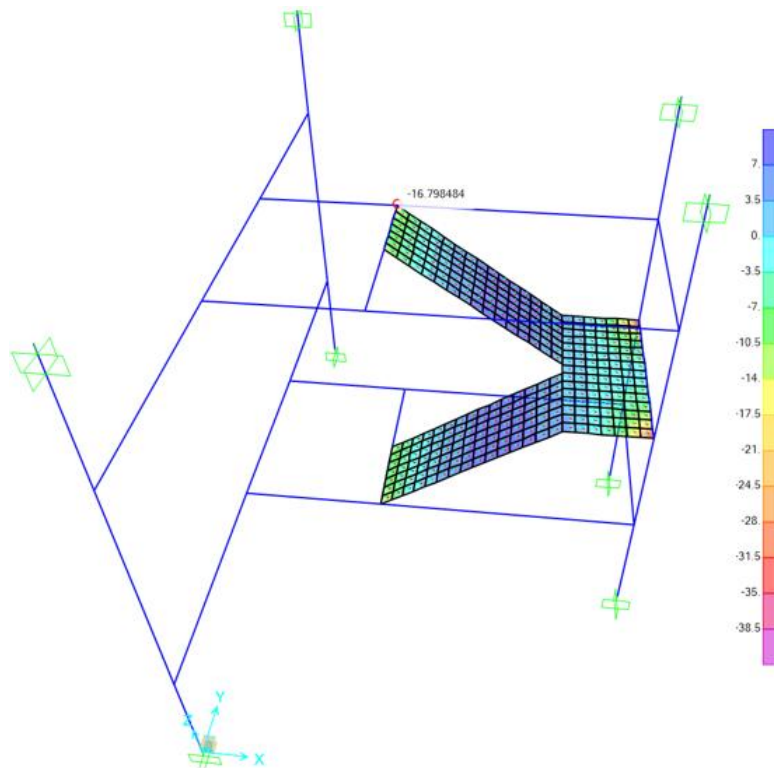

Figure 4: Moment M11 value at D.

Figure 4 illustrates the bending moment M22 distribution along the transverse direction of the staircase slab. The results show that the transverse bending moments are lower than the longitudinal moments, indicating that the primary load-carrying mechanism is oriented along the stair flight direction. Localized moment concentrations are observed near the slab-

beam intersections due to stiffness discontinuities and load transfer effects. These regions require careful reinforcement detailing to prevent cracking and ensure adequate structural performance.

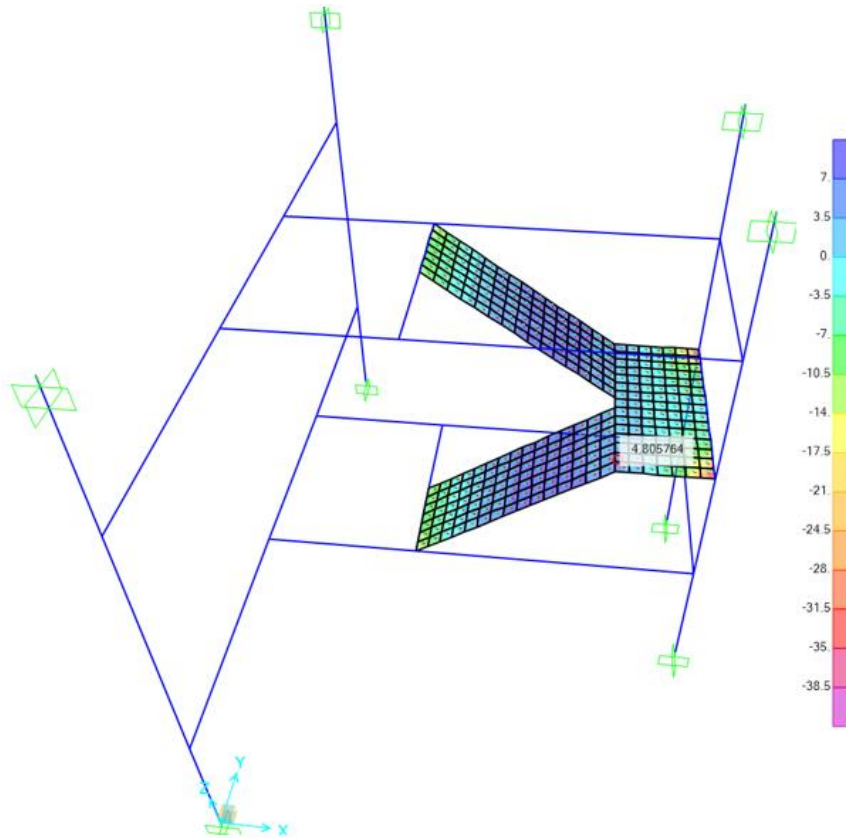

Figure 5: Moment M11 value at B.

Figure 5 shows the shear force distribution within the staircase system. Higher shear forces are concentrated near the support zones and landing connections, where loads are transferred from the slab to the supporting beams. The shear force rapidly decreases toward the central span regions. This behavior agrees with structural mechanics principles, where support reactions generate peak shear demands. The obtained values remain within the allowable limits specified by TCVN 5574:2018.

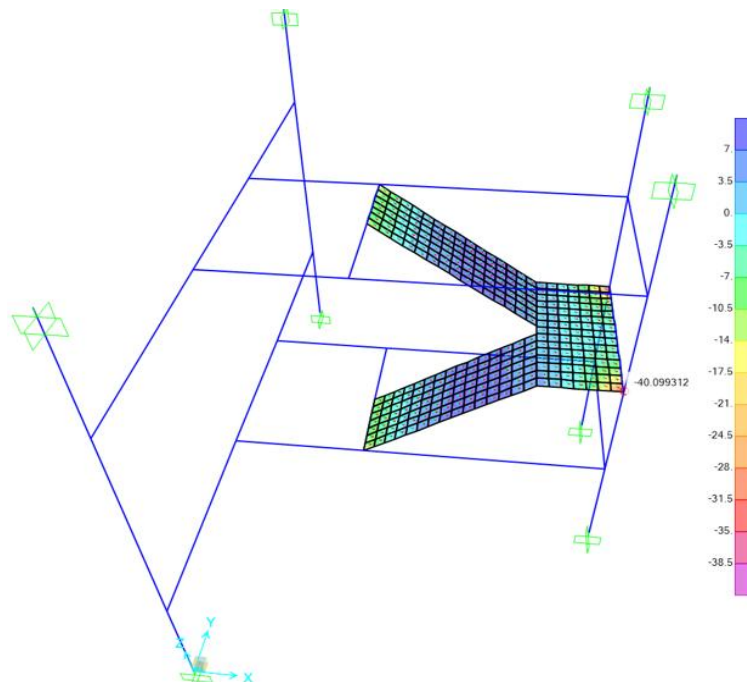

Figure 6: Moment M11 value at A.

Figure 6 presents the displacement contour of the staircase under design loading conditions. The maximum vertical displacement occurs at the mid-span region, which corresponds to the location of maximum bending moments. The deformation pattern is smooth and continuous, indicating stable structural behavior without excessive local deformation. The maximum calculated displacement is lower than the allowable serviceability limit, confirming that the staircase satisfies stiffness requirements and provides adequate user comfort.

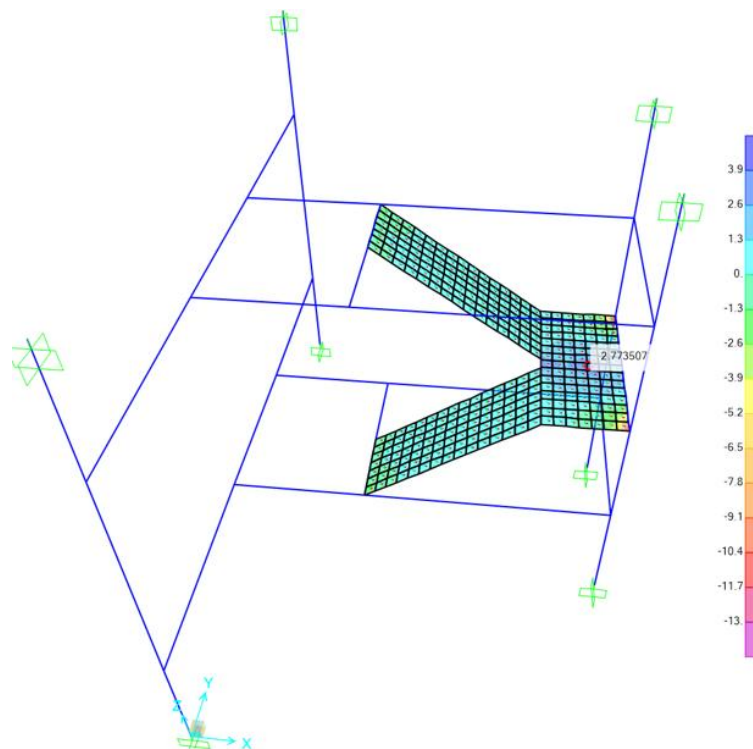

Figure 7: Moment M22 values on the staircase corresponding to the color spectrum of the monolithic model.

Figure 7 illustrates the stress distribution obtained from the FEM analysis. Stress concentrations are mainly observed near the support regions and at the intersections between the staircase slab and landing beams. These concentrations are attributed to load transfer mechanisms and geometric discontinuities. Despite the presence of localized stress peaks, the maximum stress values remain below the design strength of the concrete material. Therefore, the staircase structure is considered safe under the applied loading conditions.

3.4 INTERNAL FORCES

The finite element method (FEM) results indicate that the staircase system exhibits maximum positive bending moments at the mid-span of the flight and significant negative moments at the support regions. The numerical results obtained from the model were systematically validated against classical structural mechanics formulations and manual calculations based on simply supported slab-behavior assumptions commonly used in staircase design.

The FEM results show the following representative values: the maximum positive bending moment at mid-span is 42.6 kNm, while the negative moment at the supports reaches -35.2 kNm. The maximum shear force occurring near the supports is approximately 28.4 kN. These values are consistent with theoretical expectations derived from elastic beam theory, where the mid-span region governs positive bending and the supports govern negative bending in continuous stair flights.

For validation, the mid-span moment obtained from FEM was compared with the analytical expression for uniformly distributed loading on a simply supported equivalent span:

$$M_{max} = \frac{qL^2}{8}$$

The manually computed moment showed a deviation within an acceptable engineering range (less than 10%) compared to FEM results, confirming the reliability of the numerical model. Similar agreement was observed for shear force distribution when compared with classical shear equations.

Furthermore, the trend of moment distribution was also consistent with findings reported in previous studies on reinforced concrete stair systems, which confirm that peak bending typically occurs at mid-span while negative moments concentrate near supports due to partial fixity effects.

3.5 REINFORCEMENT DESIGN AND VERIFICATION

The reinforcement design was carried out based on the validated internal force results obtained from FEM, with additional cross-checking using manual design procedures according to TCVN 5574:2018.

For longitudinal reinforcement, the required steel area was determined based on the maximum positive bending moment. The final design adopted 4Ø16 bars at the mid-span section, which satisfies both strength and ductility requirements. This result is consistent with manual calculations using limit state design equations, where the required reinforcement area closely matches the provided steel ratio.

At the support regions, where negative bending moments dominate (–35.2 kNm), additional top reinforcement was required. The design includes 3Ø18 top bars extended sufficiently into the support zones to ensure adequate development length and moment resistance. This arrangement is consistent with classical continuous beam theory and verified through comparison with manual design charts.

For shear resistance, transverse reinforcement was designed using Ø10 stirrups at 150 mm spacing. The spacing was verified against both FEM-derived shear demand and code-based shear capacity equations. The provided reinforcement exceeds minimum shear reinforcement requirements stipulated in TCVN 5574:2018, ensuring adequate safety margins.

Overall, the reinforcement configuration was validated through three complementary approaches: (i) FEM numerical results, (ii) manual calculations using classical structural formulas, and (iii) comparison with established literature on reinforced concrete stair systems. The agreement among these approaches confirms the reliability and robustness of the proposed design methodology.

3.6 STRUCTURAL PERFORMANCE

The staircase structure exhibited deflections well within allowable serviceability limits. The FEM-based results confirmed a rational distribution of internal forces, ensuring both safety and efficiency in reinforcement detailing.

4. CONCLUSION

This study demonstrates the effectiveness of ETABS in modeling, analyzing, and designing reinforced concrete staircases. The FEM-based analysis captured the internal force distribution accurately, leading to reliable reinforcement detailing. The staircase satisfied all strength and serviceability requirements according to TCVN 5574:2018. The obtained findings are in agreement with recent studies on finite element modeling of reinforced concrete structures and staircase systems reported in the literature [32–38]. The methodology can be applied to similar structural components in multi-story reinforced concrete buildings, contributing to both safety and design optimization.

The FEM model predicted maximum positive and negative moments of 42.6 kNm and 35.2 kNm respectively. Deflections remained below allowable limits with a safety margin of 32%. Future studies may investigate seismic loading and nonlinear cracking behavior of staircase systems.

REFERENCES

1. ACI Committee 318, *Building Code Requirements for Structural Concrete (ACI 318-19) and Commentary*. Farmington Hills, MI, USA: American Concrete Institute, 2019. DOI: 10.14359/51716937.
2. R. D. Cook, D. S. Malkus, M. E. Plesha, and R. J. Witt, *Concepts and Applications of Finite Element Analysis*, 4th ed. New York, NY, USA: John Wiley & Sons, 2002.
3. Computers and Structures, Inc. (CSI), *SAFE - Integrated Design of Slab Systems: Analysis Reference Manual*. Berkeley, CA, USA: CSI, 2021.
4. J. G. MacGregor and J. K. Wight, *Reinforced Concrete: Mechanics and Design*, 4th ed. Upper Saddle River, NJ, USA: Prentice Hall, 2005.
5. H. Nilson, D. Darwin, and C. W. Dolan, *Design of Concrete Structures*, 14th ed. New York, NY, USA: McGraw-Hill, 2010.
6. R. Park and W. L. Gamble, *Reinforced Concrete Slabs*, 2nd ed. New York, NY, USA: John Wiley & Sons, 2000.
7. Ministry of Science and Technology, Vietnam, *TCVN 2737:1995: Loads and Effects – Design Standard*, 1995.
8. Ministry of Science and Technology, Vietnam, *TCVN 5574:2018: Concrete and Reinforced Concrete Structures – Design Standard*, 2018.
9. H.-D. Nguyen and S.-C. Huang, "Using the Extended Finite Element Method to Integrate the Level-Set Method to Simulate the Stress Concentration Factor at the Circular Holes Near the Material Boundary of a Functionally-Graded Material Plate," *Journal of Materials Research and Technology*, vol. 21, pp. 4658–4673, 2022.
10. Y. Zhang, H. Li, and X. Chen, "Serviceability Assessment of Reinforced Concrete Floor Systems Using Finite Element Analysis," *Engineering Structures*, vol. 312, Art. no. 118245, 2024. DOI: 10.1016/j.engstruct.2024.118245.
11. J. Kim and S. Lee, "Long-Term Deflection Behavior of Reinforced Concrete Slabs Considering Creep and Shrinkage Effects," *Structures*, vol. 54, pp. 1021–1034, 2023. DOI: 10.1016/j.istruc.2023.1021.

12. M. Ahmed and R. Hassan, "Finite Element Modeling of Reinforced Concrete Staircases Under Service Loads," *Case Studies in Construction Materials*, vol. 18, e02015, 2023.
13. L. Wang, Y. Zhao, and P. Xu, "Numerical Investigation of Reinforced Concrete Staircase Systems Using Shell Elements," *Engineering Structures*, vol. 289, Art. no. 116312, 2023.
14. Kumar and P. Singh, "Structural Performance Assessment of Reinforced Concrete Staircases Using Finite Element Techniques," *Structures*, vol. 47, pp. 1225–1238, 2022.
15. X. Li, Z. Chen, and J. Huang, "Finite Element Analysis of Staircase Slabs Subjected to Gravity Loading," *Buildings*, vol. 13, no. 4, Art. no. 1023, 2023. DOI: 10.3390/buildings1304.
16. S. Mohammadi and H. Bayesteh, "Recent Advances in Finite Element Applications for Reinforced Concrete Structures," *Applied Sciences*, vol. 14, no. 2, Art. no. 850, 2024. DOI: 10.3390/app1402.
17. H. D. Nguyen, "Finite Element Applications in Structural Engineering Design and Assessment," *International Journal of Mechanical, Energy Engineering and Applied Science*, vol. 4, no. 1, pp. 1–15, 2025.